

Assembly Instruction

Loveseat

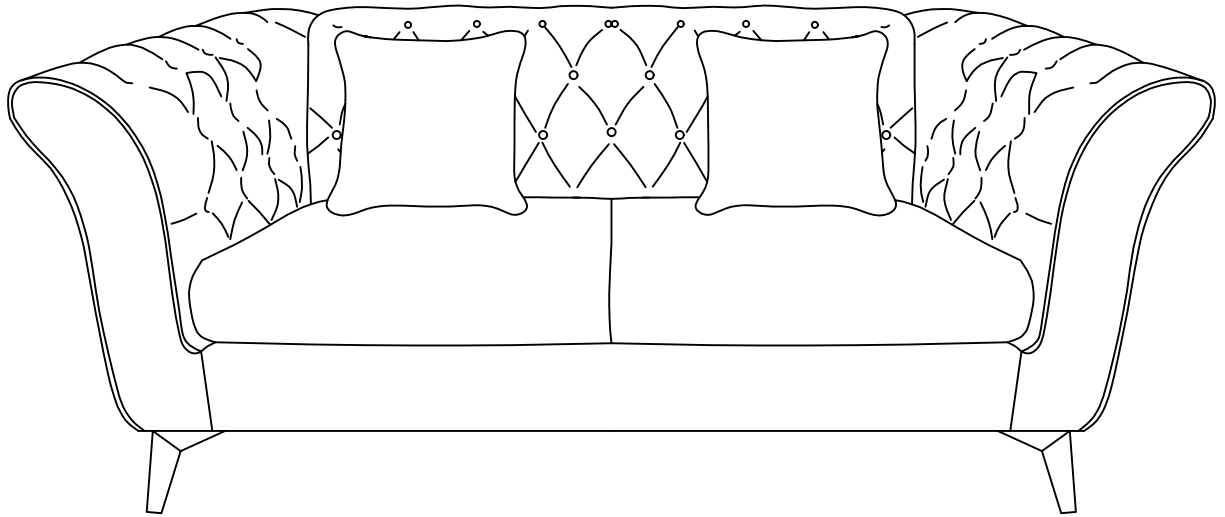

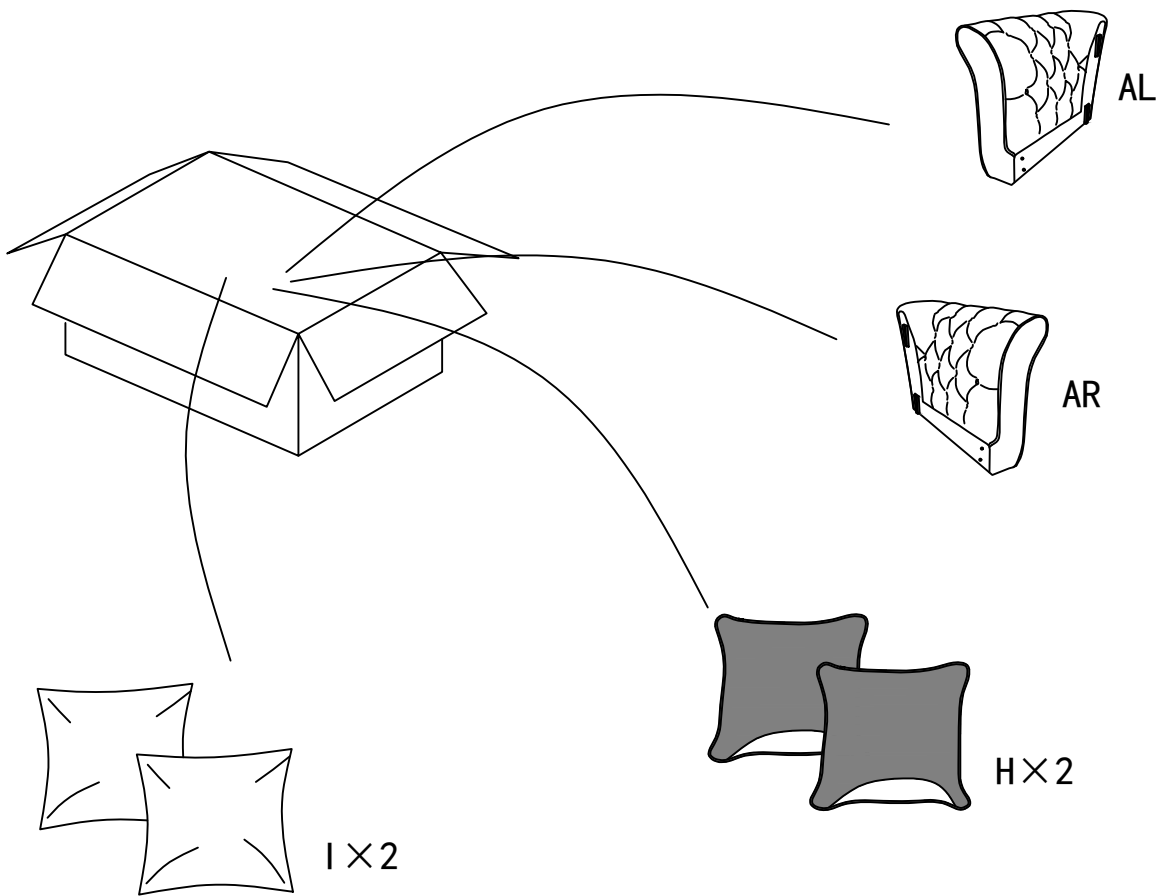

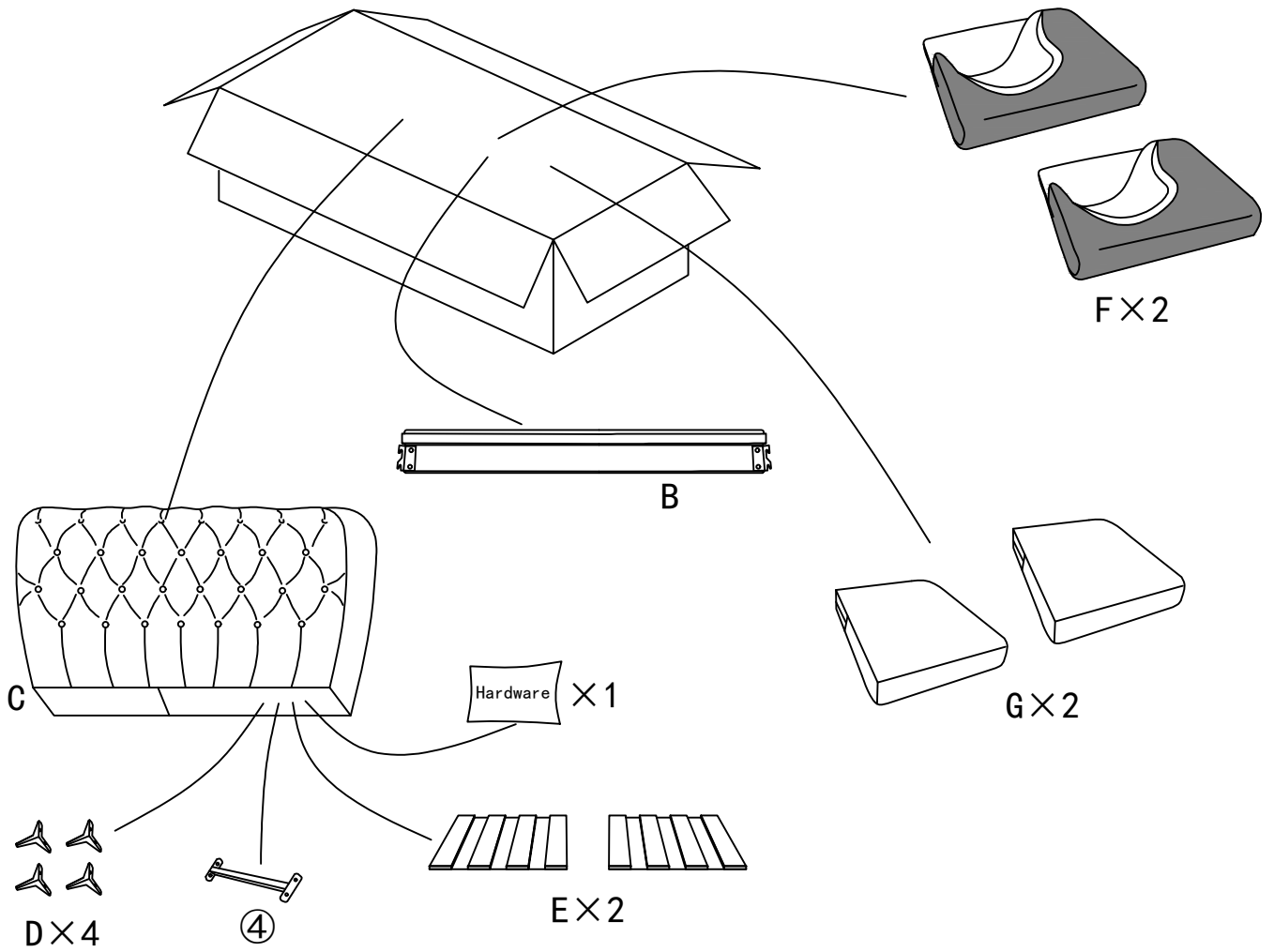

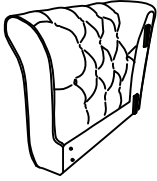
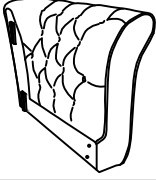
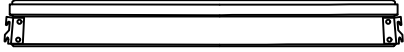
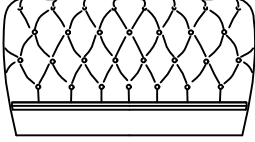
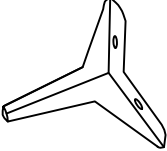
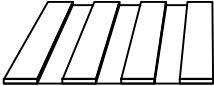
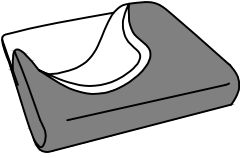
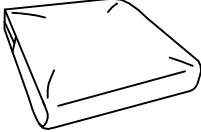
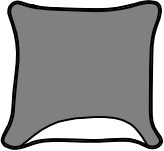
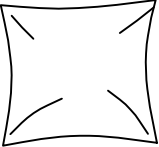

Parts List



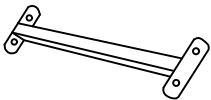

Label	Picture	Description	QTY
AL		Left Armrest	1
AR		Right Armrest	1
B		Front Rail	1
C		Backrest	1
D		Leg	4
E		Slats	2
F		Seat Cover	2
G		Cover Core	2
H		Pillow Cover	2
I		Pillow Core	2

Hardware

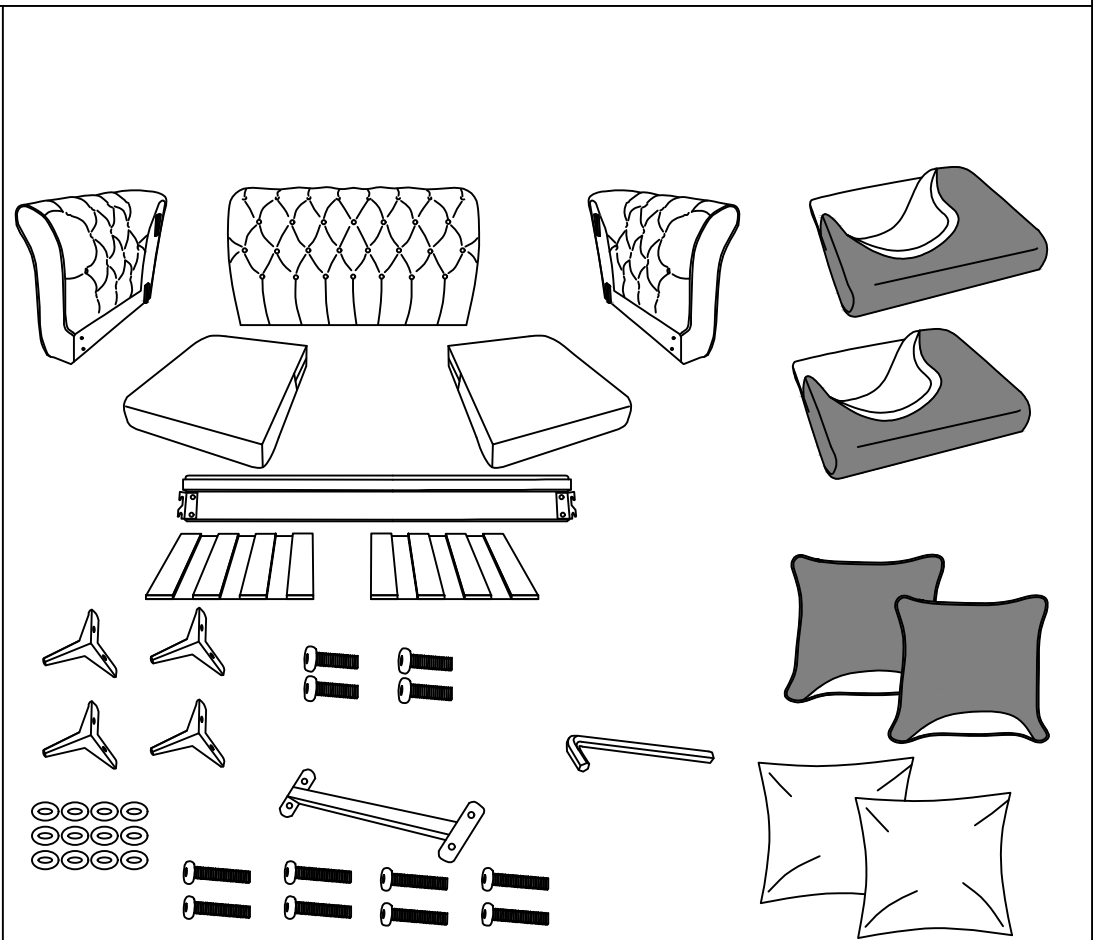
Label	Picture	Description	QTY
①		Bolt (M8*15MM)	4
②		Washer	12
③		Allen Key	1
④		Supporting pole	1
⑤		Bolt (M8*30MM)	8

Assembly Preparation



-  ● Read instructions, cover to cover.
-  ● Have 2 adults for assembly.
-  ● Do not assemble on flooring or carpet.
-  ● Assemble on a clean non-marring surface (packing foam).
-  ● Save all packaging until finished.

Step1

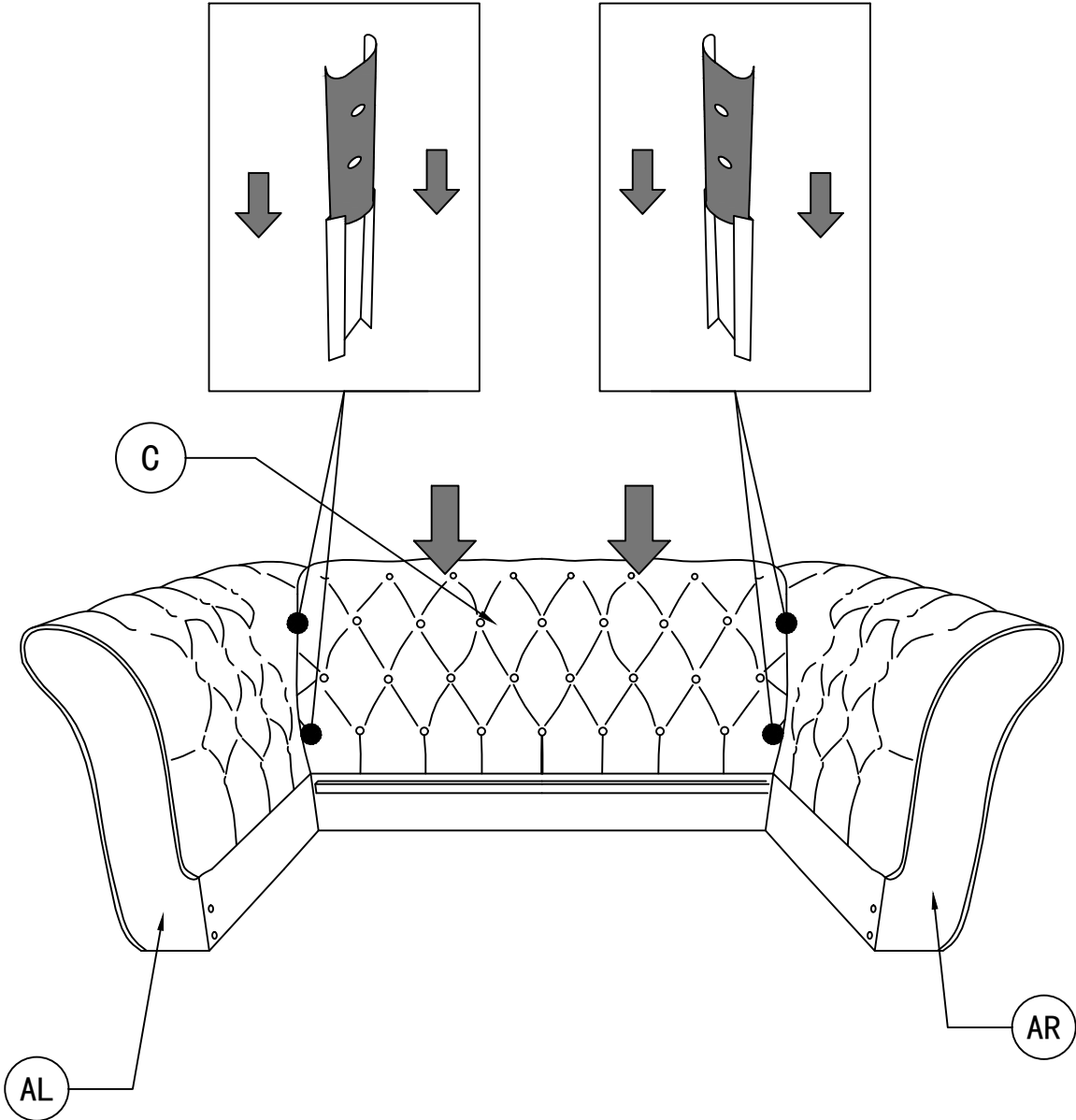

Step2

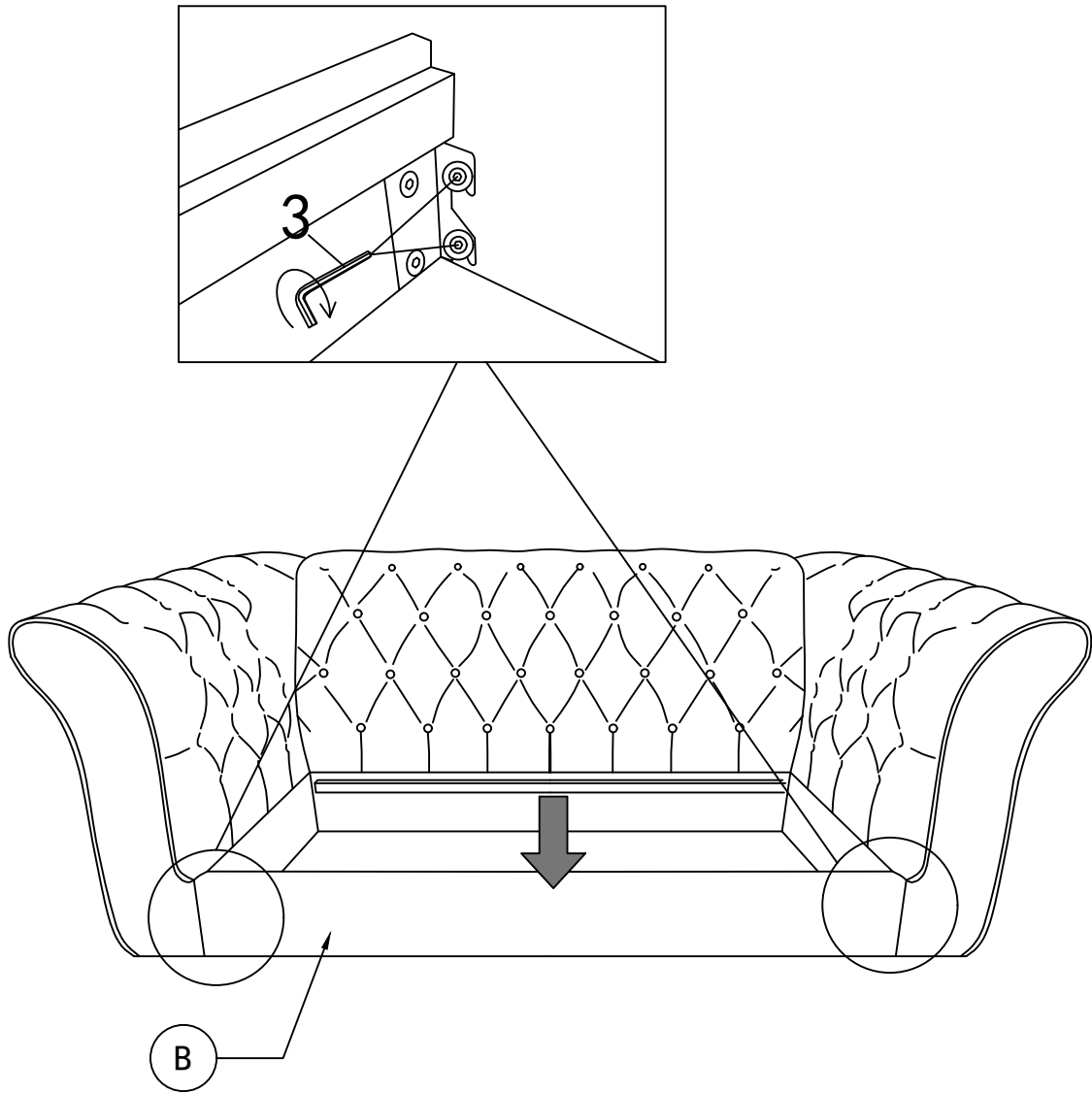

Step3

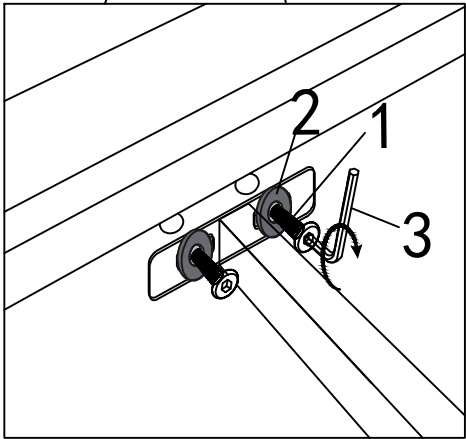
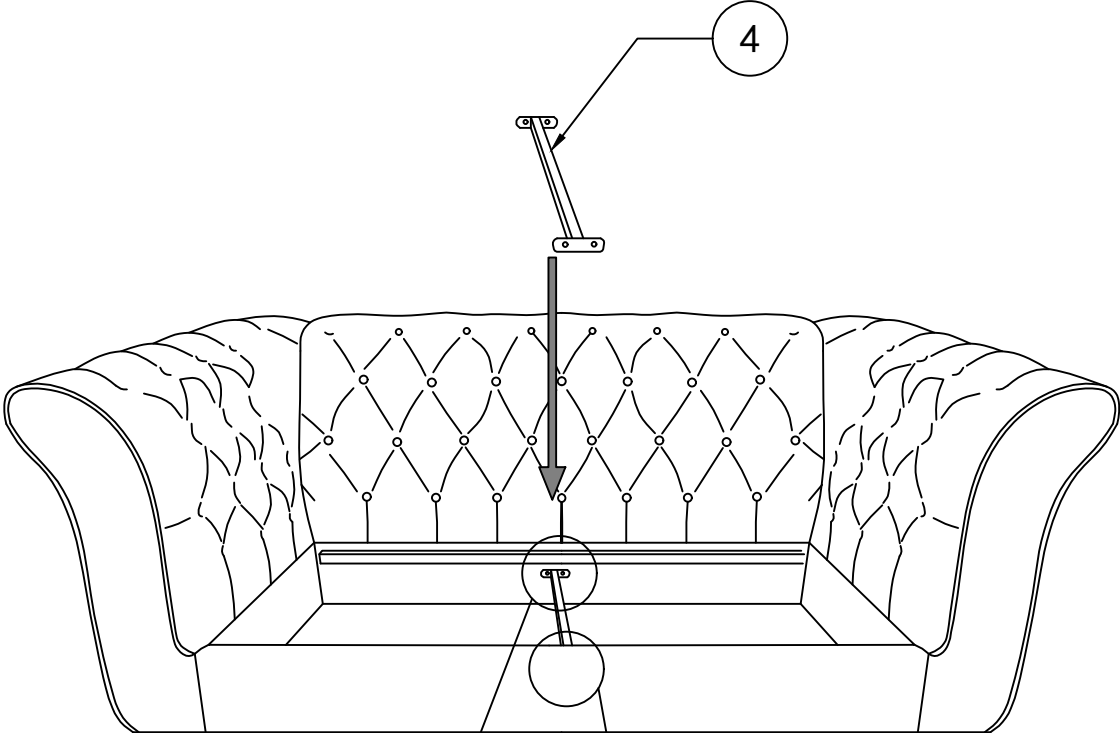

Step4

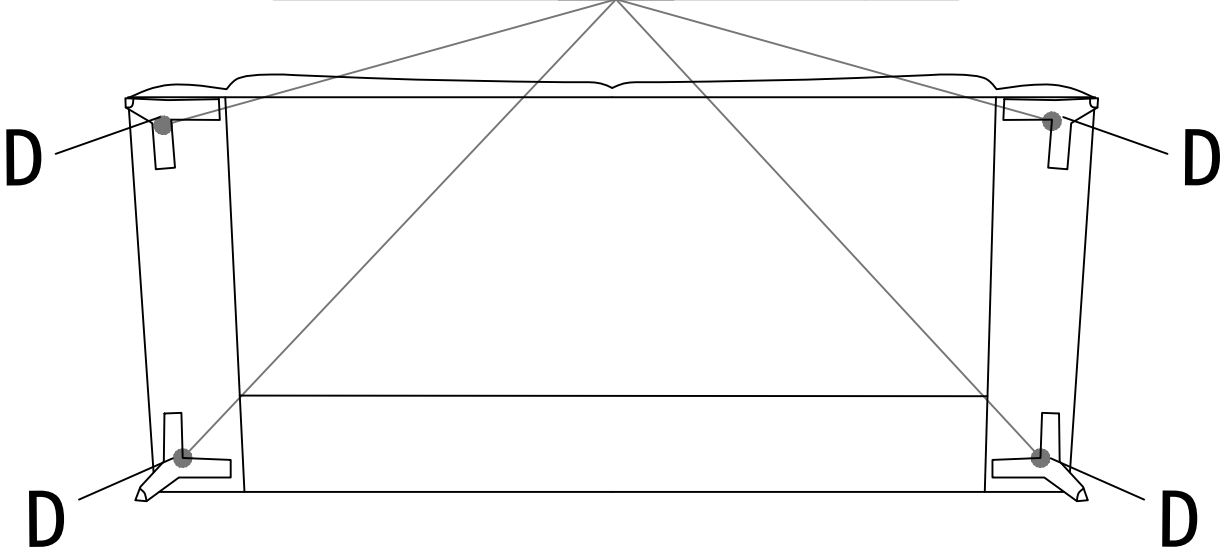
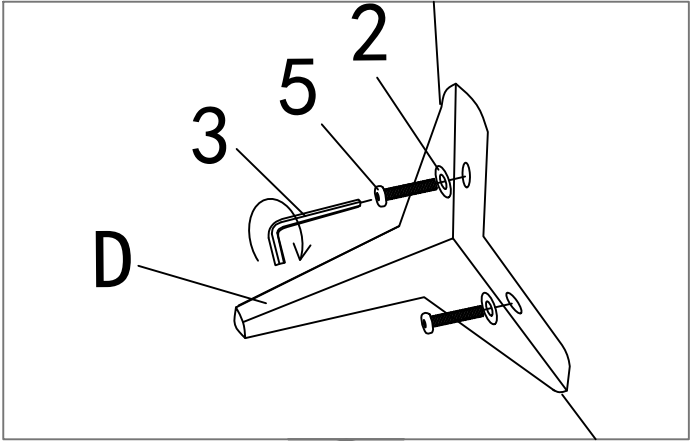
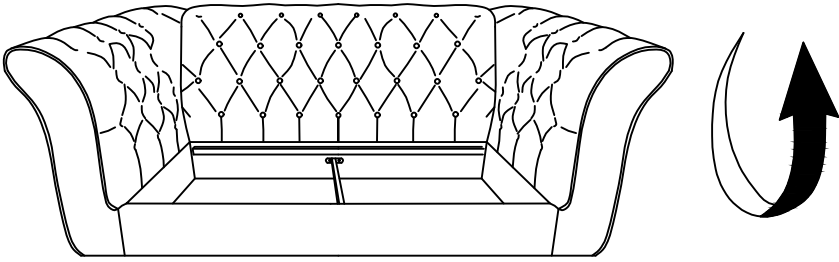

Step5

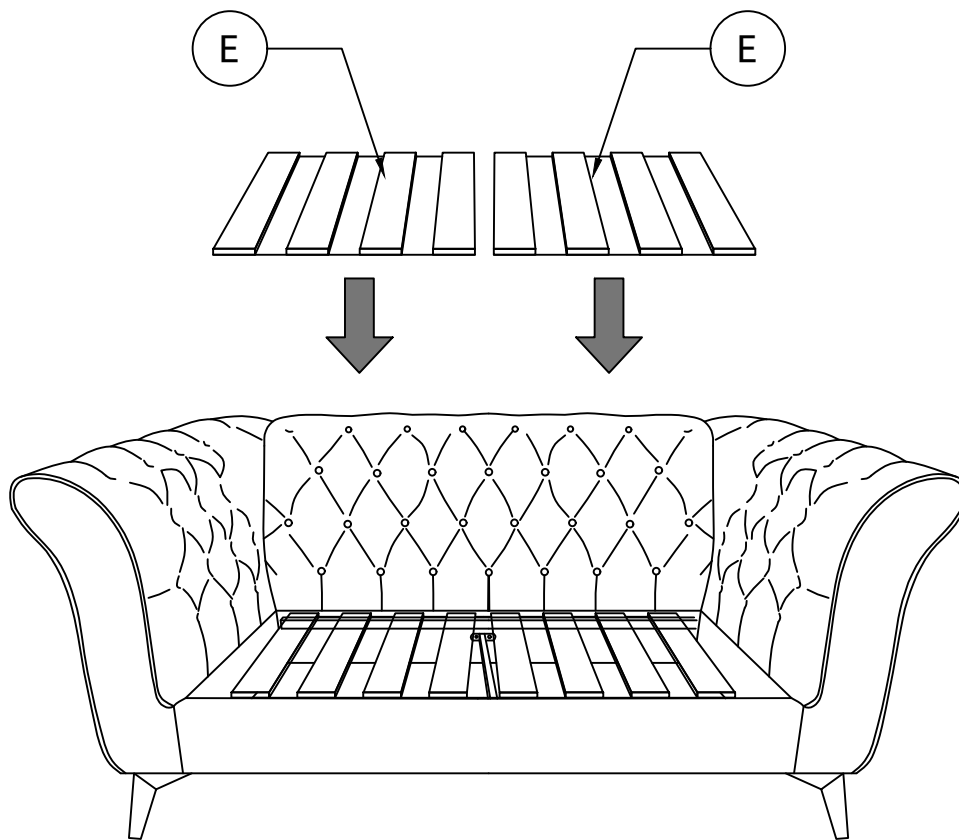

Step6

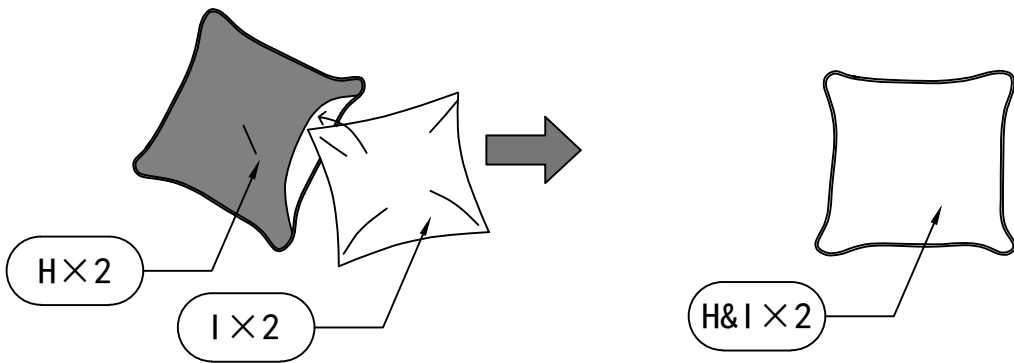
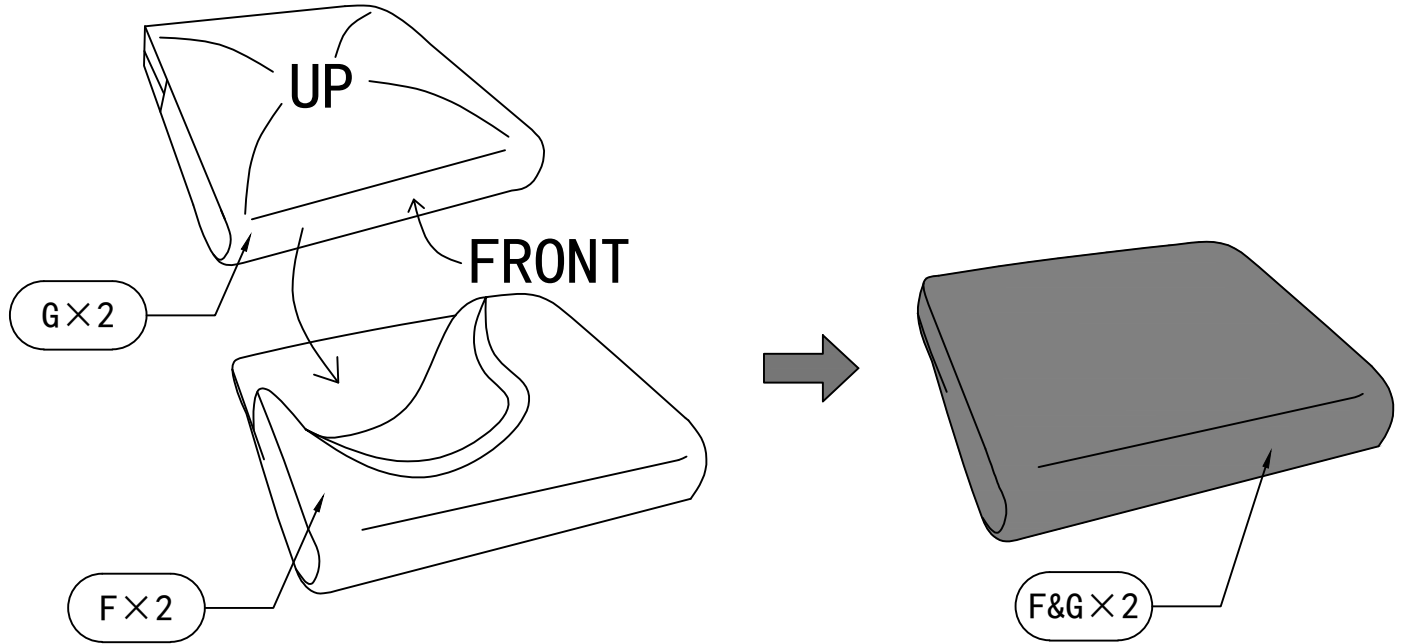
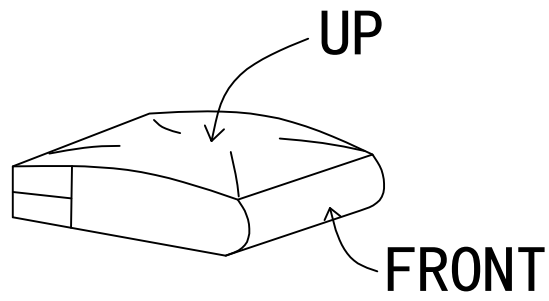

Step7

